



Product Specifications

Receiving card

HD-R512S

V2.0 20200303

1. Overview

R512S, on-board 12*HUB75E ports, compatible with R500/R508/R512/R516/R612.

2. Parameters

With sending card	Dual-mode sending box, Asynchronous sending card, Synchronous sending card, Video processor of VP series.
Module type	Compatible with all common IC module, supported most PWM IC module.
Scan mode	Supports any scanning method from static to 1/64 scan
Communication method	Gigabit Ethernet
Control range	Recommend: 256*256 pixels Outdoor module width ≤ 256 , Indoor module width ≤ 128
Multi-card connection	Receiving card can be put in any sequence
Gray scale	256~65536
Smart setting	A few simple steps to complete the smart settings, through the screen layout can be set to go with any alignment of the screen unit board
Test functions	Receiving card integrated screen test function, Test display brightness uniformity and display module flatness.
Communication distance	Super Cat5,Cat6 network cable within 146 meters
Port	5V DC Power*2,1Gbps Ethernet port*2, HUB75E*12
Input voltage	4V-6V
Power	5W

3. Connection Method

Connection diagram of connecting R512S with display player box:

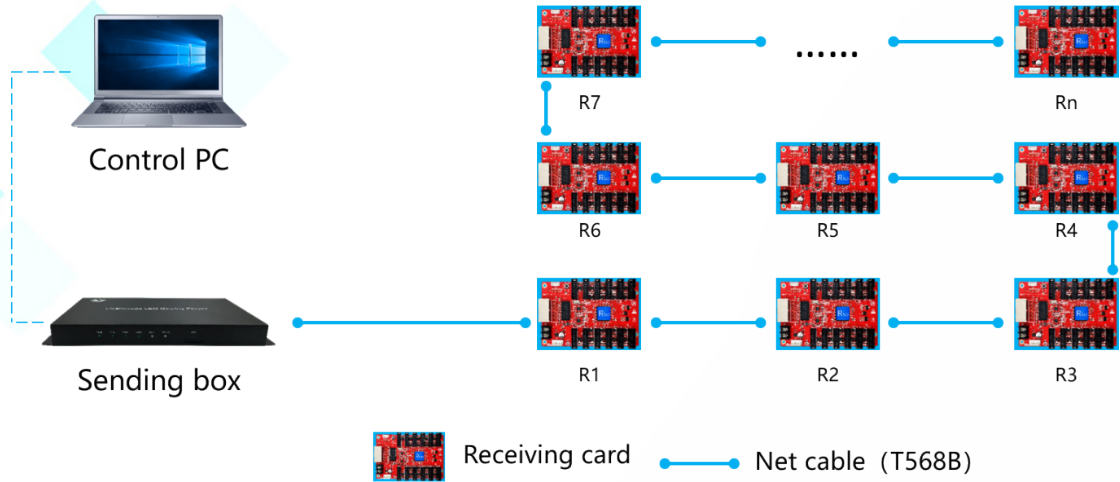

4. Dimensions

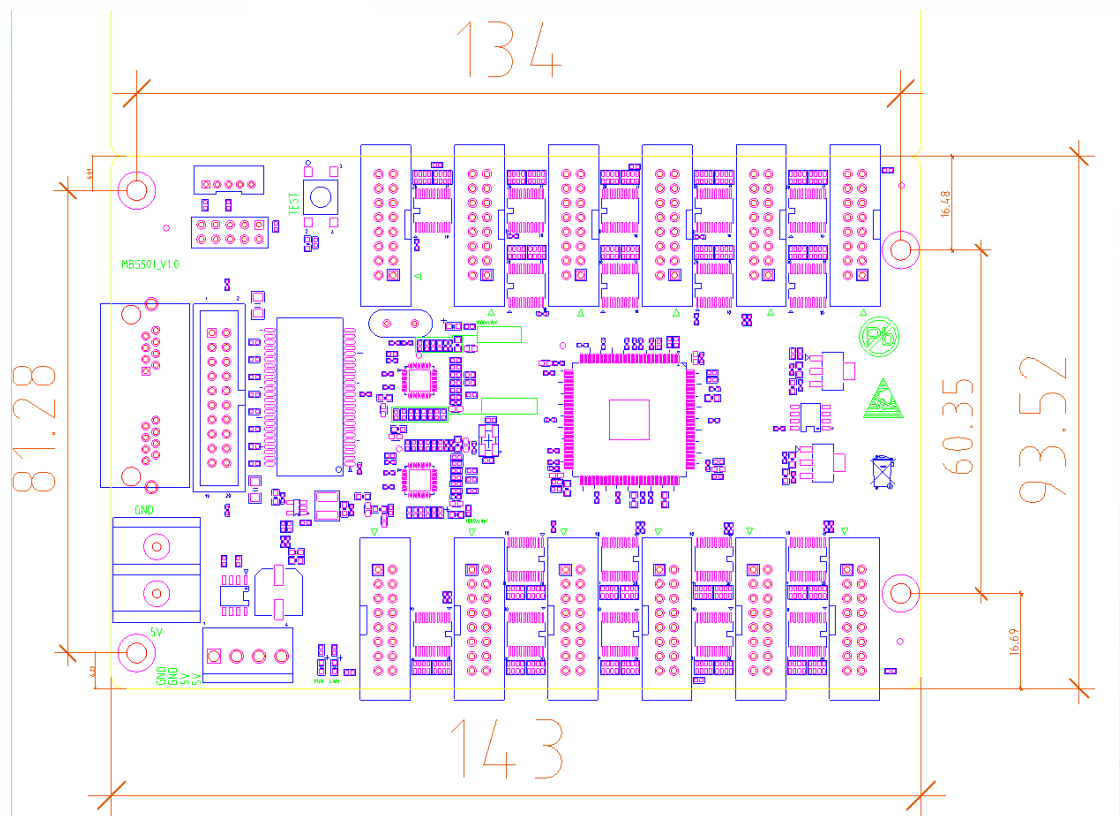

5. Interface Definition

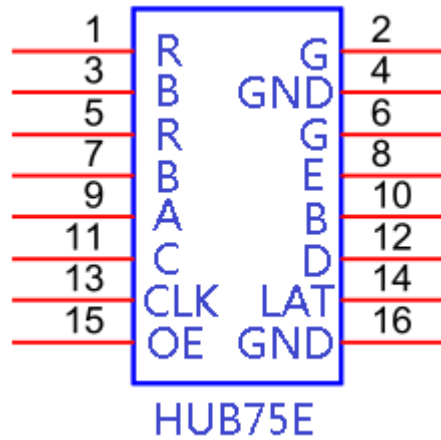

6. Appearance Description

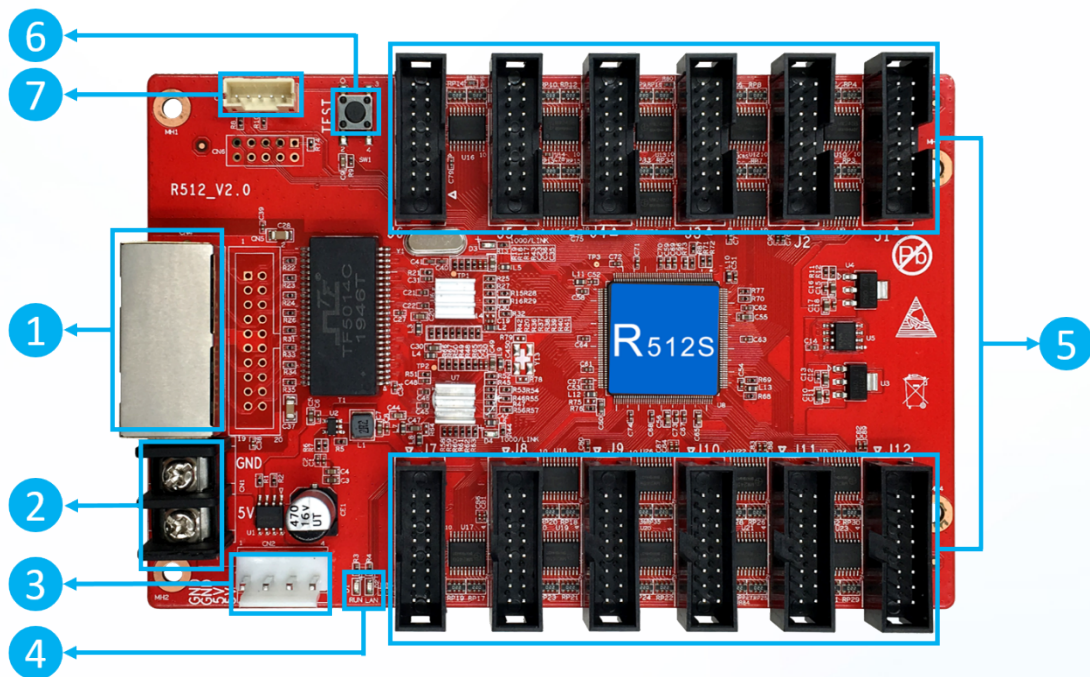

①： Gigabit Ethernet port, used to connect the sending card or receiving card, the same two network ports are interchangeable,

②： Power interface, can be accessed with 4.5V ~ 5.5V DC voltage;

- ③： Power interface, can be accessed with 4.5V ~ 5.5V DC voltage; (②,③ connect one of them is ok.)
- ④： Work indicator, D1 flashes to indicate that the control card is running normally; D2 flashes quickly to indicate that Gigabit has been recognized and data is being received.
- ⑤： HUB75Eport, connect to the modules,
- ⑥： Test button, used to test display brightness uniformity and display module flatness.
- ⑦： External indicator light, run light and data light.

7. Technical Parameters

	Minimum	Typical	Maximum
Rated voltage(V)	4.2	5.0	5.5
Storage temperature(°C)	-40	25	105
Work environment temperature(°C)	-40	25	80
Work environment humidity (%)	0.0	30	95
Net weight (kg)	0.091		
Certificate	CE, FCC, RoHS		

Precautions

- 1) ensure the system long-term stable running, please keep to use the standard 5V power supply voltage.