

# Product specification

Receiving card

**HD-R5S**

V0.1 20191111

## 1. Overview

R5S is a small-size receiving card for LED transparent screen and fine pixel pitch LED screen control launched by Huidu Technology. A single card supports control of 256\*512 pixels, and it can be cascaded with any Huidu sending card

## 2. Parameters Table

<b>With sending card</b>	Dual-mode sending box, Asynchronous sending card, Synchronous sending card, Video processor of VP series.
<b>Module type</b>	Supports transparent screen modules for all normal chips and mainstream PWM chips.
<b>Scan Mode</b>	Support any scanning method from static to 1/64, support extraction and empty point setting.
<b>Communication</b>	Gigabit Ethernet port
<b>Control Range</b>	Recommend: 256*512
<b>Multiple cards cascaded</b>	Receiving cards can be arbitrarily Sort, synchronized in nanoseconds
<b>Gray Scale</b>	Support 256~65536 (adjustable)
<b>Smart setting</b>	A few simple steps to complete the smart setting, and the display module can be matched with any wiring mode through the screen body routing setting.
<b>Communication distance</b>	Super category 5 , Super category 6 network cable is within 100 meters
<b>Port</b>	120PIN*2
<b>Input voltage</b>	4V-6V
<b>Power</b>	5W

### 3. Connection Method

Schematic diagram of connection between sending box and receiving card:

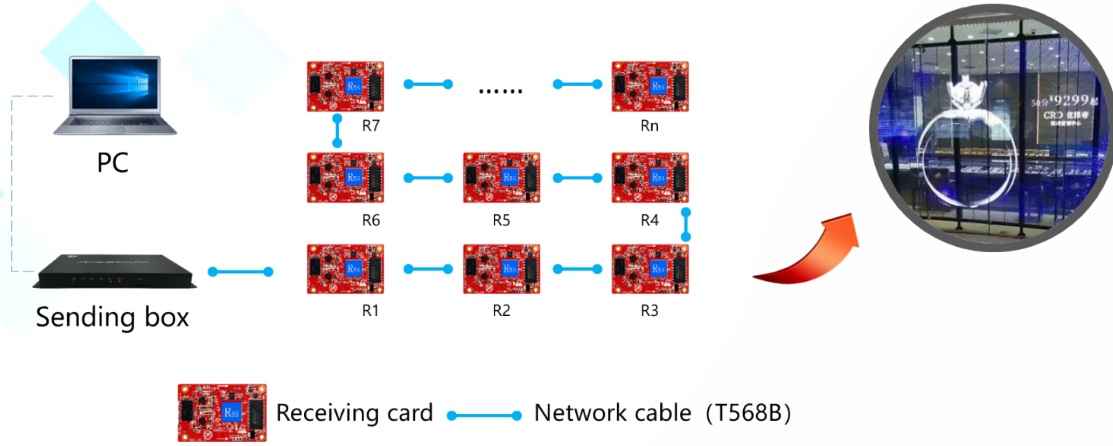

### 4. Appearance Description

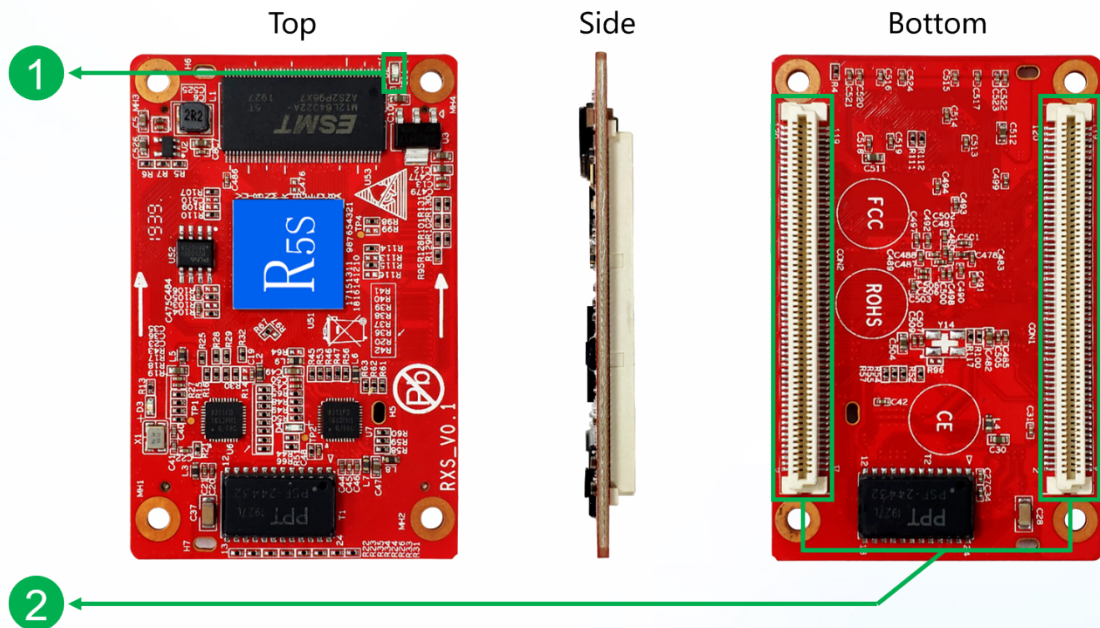

- ① Running light : the light flashes when the control card is working normally;
- ② Data interface: Data signal transfer interface, which is connected with the transfer board.

## 5. Dimensions Chart

Front view

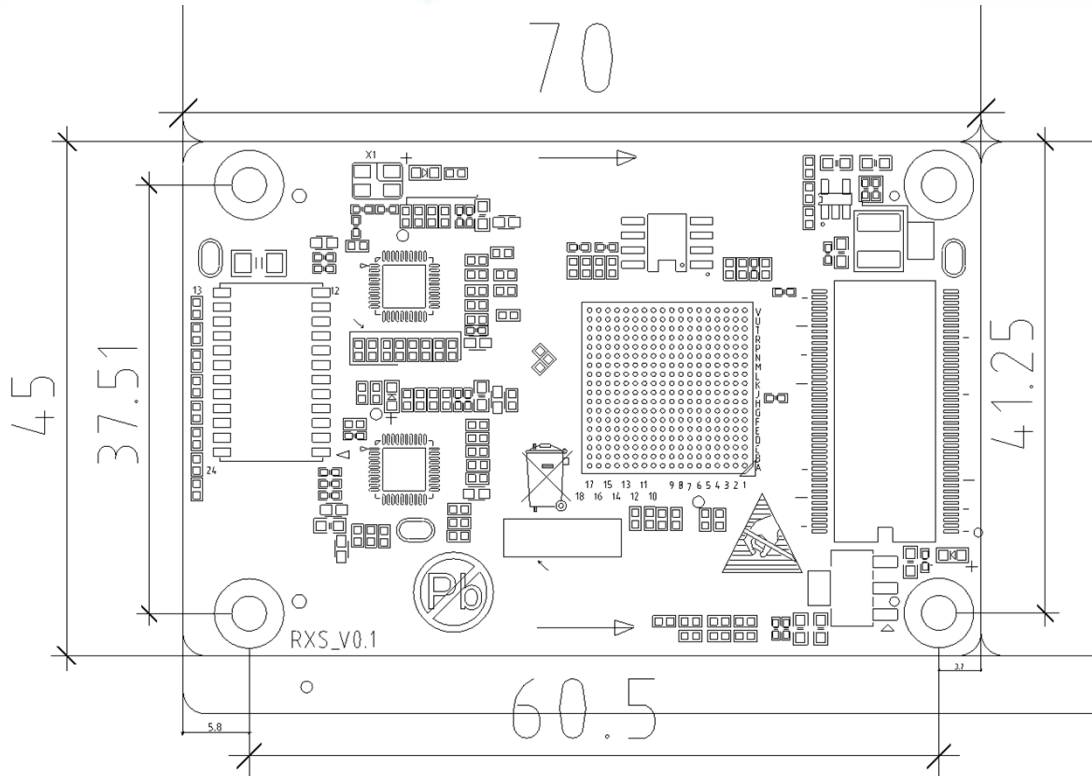

Back view

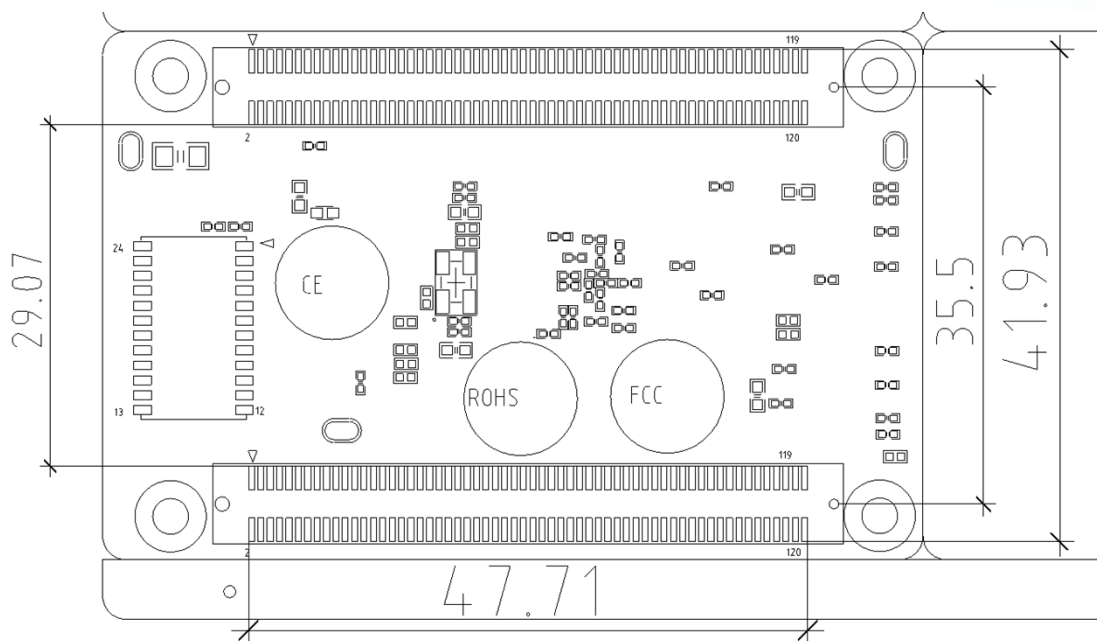

## 6. Interface definition

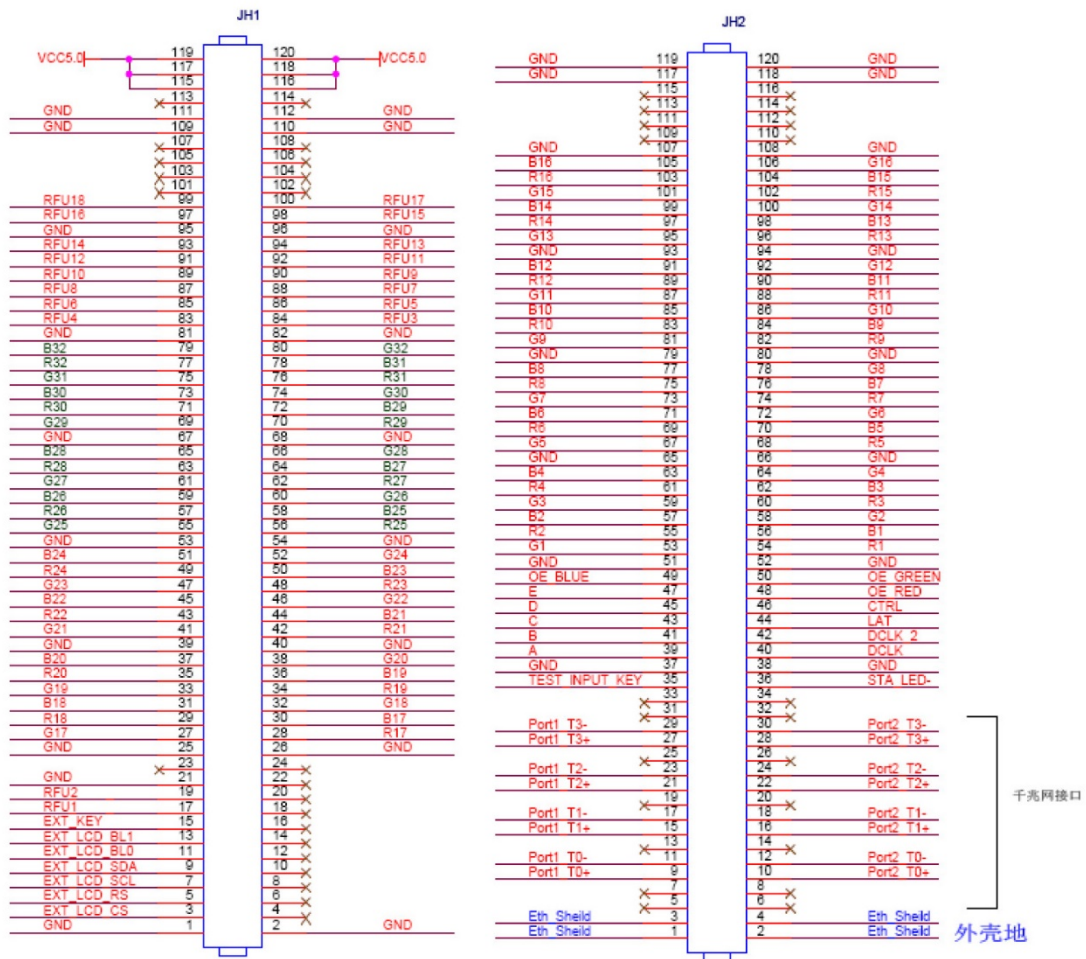

## 32 Groups sets of parallel data interface definitions

JH1			
GND	1	2	GND
EXT_LCD_CS	3	4	NC
EXT_LCD_RS	5	6	NC
EXT_LCD_SCL	7	8	NC
EXT_LCD_SDA	9	10	NC
EXT_LCD_BL0	11	12	NC
EXT_LCD_BL1	13	14	NC
EXT_KEY	15	16	NC
RFU1	17	18	NC
RFU2	19	20	NC
GND	21	22	NC
NC	23	24	NC
GND	25	26	GND
G17	27	28	R17
R18	29	30	B17
B18	31	32	G18
G19	33	34	R19
R20	35	36	B19
B20	37	38	G20
GND	39	40	GND
G21	41	42	R21
R22	43	44	B21
B22	45	46	G22
G23	47	48	R23
R24	49	50	B23
B24	51	52	G24
GND	53	54	GND
G25	55	56	R25
R26	57	58	B25
B26	59	60	G26
G27	61	62	R27
R28	63	64	B27
B28	65	66	G28
GND	67	68	GND
G29	69	70	R29
R30	71	72	B29
B30	73	74	G30
G31	75	76	R31
R32	77	78	B31
B32	79	80	G32
GND	81	82	GND
RFU4	83	84	RFU3
RFU6	85	86	RFU5
RFU8	87	88	RFU7
RFU10	89	90	RFU9
RFU12	91	92	RFU11
RFU14	93	94	RFU13
GND	95	96	GND
RFU16	97	98	RFU15
RFU18	99	100	RFU17
NC	101	102	NC
NC	103	104	NC
NC	105	106	NC
NC	107	108	NC
GND	109	110	GND
GND	111	112	GND
NC	113	114	NC
VCC	115	116	VCC
VCC	117	118	VCC
VCC	119	120	VCC

JH2			
Eth_Sheild	1	2	Eth_Sheild
Eth_Sheild	3	4	Eth_Sheild
NC	5	6	NC
NC	7	8	NC
Port1_T0+	9	10	Port2_T0+
Port1_T0-	11	12	Port2_T0-
NC	13	14	NC
Port1_T1+	15	16	Port2_T1+
Port1_T1-	17	18	Port2_T1-
NC	19	20	NC
Port1_T2+	21	22	Port2_T2+
Port1_T2-	23	24	Port2_T2-
NC	25	26	NC
Port1_T3+	27	28	Port2_T3+
Port1_T3-	29	30	Port2_T3-
NC	31	32	NC
NC	33	34	NC
TEST_INPUT_KEY	35	36	STA_LED-
GND	37	38	GND
A	39	40	DCLK
B	41	42	DCLK_2
C	43	44	LAT
D	45	46	CTRL
E	47	48	OE_RED
OE_BLUE	49	50	OE_GREEN
GND	51	52	GND
G1	53	54	R1
R2	55	56	B1
B2	57	58	G2
G3	59	60	R3
R4	61	62	B3
B4	63	64	G4
GND	65	66	GND
G5	67	68	R5
R6	69	70	B5
B6	71	72	G6
G7	73	74	R7
R8	75	76	B7
B8	77	78	G8
GND	79	80	GND
G9	81	82	R9
R10	83	84	B9
B10	85	86	G10
G11	87	88	R11
R12	89	90	B11
B12	91	92	G12
GND	93	94	GND
G13	95	96	R13
R14	97	98	B13
B14	99	100	G14
G15	101	102	R15
R16	103	104	B15
B16	105	106	G16
GND	107	108	GND
NC	109	110	NC
NC	111	112	NC
NC	113	114	NC
NC	115	116	NC
GND	117	118	GND
GND	119	120	GND

## 64 Groups serial data interface definition

JH1			
GND	1	2	GND
EXT_LCD_CS	3	4	NC
EXT_LCD_RS	5	6	NC
EXT_LCD_SCL	7	8	NC
EXT_LCD_SDA	9	10	NC
EXT_LCD_BL0	11	12	NC
EXT_LCD_BL1	13	14	NC
EXT_KEY	15	16	NC
RFU1	17	18	NC
RFU2	19	20	NC
GND	21	22	NC
NC	23	24	NC
GND	25	26	GND
Data50	27	28	Data49
Data52	29	30	Data51
Data54	31	32	Data53
Data56	33	34	Data55
Data58	35	36	Data57
Data60	37	38	Data59
GND	39	40	GND
Data62	41	42	Data61
Data64	43	44	Data63
NC	45	46	NC
NC	47	48	NC
NC	49	50	NC
NC	51	52	NC
GND	53	54	GND
NC	55	56	NC
NC	57	58	NC
NC	59	60	NC
NC	61	62	NC
NC	63	64	NC
NC	65	66	NC
GND	67	68	GND
NC	69	70	NC
NC	71	72	NC
NC	73	74	NC
NC	75	76	NC
NC	77	78	NC
NC	79	80	NC
GND	81	82	GND
RFU4	83	84	RFU3
RFU6	85	86	RFU5
RFU8	87	88	RFU7
RFU10	89	90	RFU9
RFU12	91	92	RFU11
RFU14	93	94	RFU13
GND	95	96	GND
RFU16	97	98	RFU15
RFU18	99	100	RFU17
NC	101	102	NC
NC	103	104	NC
NC	105	106	NC
NC	107	108	NC
GND	109	110	GND
GND	111	112	GND
NC	113	114	NC
VCC	115	116	VCC
VCC	117	118	VCC
VCC	119	120	VCC

JH2			
Eth_Sheild	1	2	Eth_Sheild
Eth_Sheild	3	4	Eth_Sheild
NC	5	6	NC
NC	7	8	NC
Port1_T0+	9	10	Port2_T0+
Port1_T0-	11	12	Port2_T0-
NC	13	14	NC
Port1_T1+	15	16	Port2_T1+
Port1_T1-	17	18	Port2_T1-
NC	19	20	NC
Port1_T2+	21	22	Port2_T2+
Port1_T2-	23	24	Port2_T2-
NC	25	26	NC
Port1_T3+	27	28	Port2_T3+
Port1_T3-	29	30	Port2_T3-
NC	31	32	NC
NC	33	34	NC
TEST_INPUT_KEY	35	36	STA_LED-
GND	37	38	GND
A	39	40	DCLK
B	41	42	DCLK_2
C	43	44	LAT
D	45	46	CTRL
E	47	48	OE_RED
OE_BLUE	49	50	OE_GREEN
GND	51	52	GND
Data2	53	54	Data1
Data4	55	56	Data3
Data6	57	58	Data5
Data8	59	60	Data7
Data10	61	62	Data9
Data12	63	64	Data11
GND	65	66	GND
Data14	67	68	Data13
Data16	69	70	Data15
Data18	71	72	Data17
Data20	73	74	Data19
Data22	75	76	Data21
Data24	77	78	Data23
GND	79	80	GND
Data26	81	82	Data25
Data28	83	84	Data27
Data30	85	86	Data29
Data32	87	88	Data31
Data34	89	90	Data33
Data36	91	92	Data35
GND	93	94	GND
Data38	95	96	Data37
Data40	97	98	Data39
Data42	99	100	Data41
Data44	101	102	Data43
Data46	103	104	Data45
Data48	105	106	Data47
GND	107	108	GND
NC	109	110	NC
NC	111	112	NC
NC	113	114	NC
NC	115	116	NC
GND	117	118	GND
GND	119	120	GND

## 7. Technical Parameters

	Minimum	Typical	Maximum
<b>Rated voltage(V)</b>	4.2	5.0	5.5
<b>Storage temperature(°C)</b>	-40	25	105
<b>Work environment temperature(°C)</b>	-40	25	80
<b>Work environment humidity (%)</b>	0.0	30	95
<b>Net weight (kg)</b>	0.016		
<b>Certificate</b>	CE, FCC, RoHS		

### Precaution:

- 1) To ensure the long-term stable operation of the system, please use a standard 5V power supply voltage as much as possible.